

technagon

charged by innovation

# TEP4 HAK

→ AC Charger  
Technagon TEP4  
HAK



# Features & functions

---

- Charging station with 2 charging points for public and semi-public areas
- Attached additional housing with integrated house connection box and meter cabinet (configurable as required)
- Max. charging capacity: 44 kW (2 x 22 kW) | Configurable by qualified electrician
- KfW eligible
- AFIR and calibration law compliant, controllable in accordance with §14a EnWG
- Unique, modular concept enables simple handling of the issues of service and calibration law
- Ethernet connection (LAN) and mobile modem (4G) standard
- Connection of all leading backend providers via OCPP1.6
- Available with permanently installed spiral cable
- Plug release in the event of a power failure
- Lockable front panel with profile half cylinder
- LED topper with color and flashing codes for status display
- Powder-coated aluminum housing - complete DB703
- 4.3 inch color display and RFID reader per charging point
- Display of static and dynamic QR code possible
- Intuitive and language-independent user guidance
- Integration of a universal payment terminal (credit card, Girocard, fleet cards, Apple or Google Pay)
- Load management in various stages included
- Simple connection to the domestic junction box from below
- Prefabricated foundation available as an accessory
- Meter cabinet can be individually configured

# Modular & versatile

---



- heart of the Technagon P/W series
- unique, innovative design
- certified according to calibration law
- revolutionary service concept
- intuitive user guidance on the display
- symbolic and language-independent
- in-house charging controller integrated



The Technagon TEP4 HAK offers sufficient space for a house connection box (HAK) and meter cabinet thanks to the attached additional housing. The HAK enables energy suppliers to connect directly to the charging station, making the charging pole absolutely flexible in terms of location.

# Highlight

---

The unique **charging module** opens up completely new possibilities in charging technology. Certified as a closed component, it makes it easier to comply with calibration law and revolutionizes service.

The integrated, fifth-generation **charging controller** developed in-house is the heart of this unit. Thanks to independent access to the software, we are able to ensure that our solutions always comply with standards.



modular design



Technagon charging module  
(calibration law compliant)

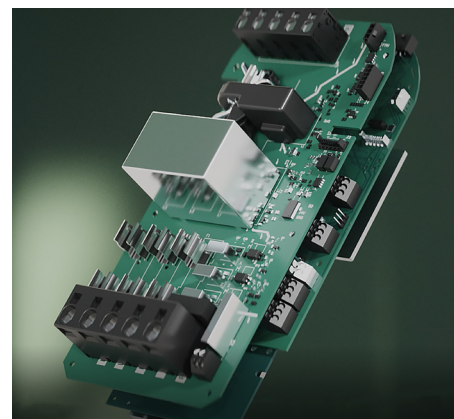

Technagon charging controller  
(5th generation)

# Basic variant

---



With charging socket as standard



With spiral cable as an option



Compliant with calibration law  
as standard



charged by innovation

# Dimensions ( mm )

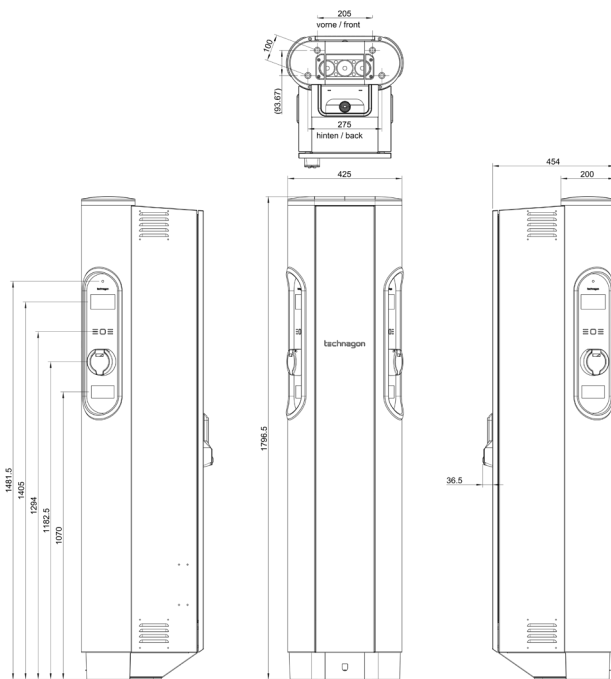

## Technical information

### Packaging

Packaging dimensions and unit	L x W x H: 1850 x 640 x 575 mm (packaging box); 2000 x 700 x 125 mm (pallet); 1x TEP4 HAK on pallet (height: 700 mm) - not stackable
Scope of delivery	Charging station, printed instructions, foundation installation set, 2x keys, master key

### Performance features and functions

Authentication	via RFID cards (ISO 14443) MIFARE Ultralight, Classic or DESFire
Screen	4.3-inch display per charging point to show operator data, prices, QR codes
Charging connections	2 x IEC 62196 type 2 charging socket plug interlock; 2 x attached type 2 cable (charging connections can be combined); *max. 2 x 22 kW in parallel, max. 32 A per charging point; (*simultaneity factor 0.9); emergency release in the event of a power failure
Charging power house connection box	Single-occupancy meter panel: 1 x 22 kW single or 2 x 13.5 kW parallel due to 44A continuous operation in accordance with VDE-AR-N 4100   Double-occupancy meter panel: 2 x 22 kW parallel meter type 30 kW variant: 1x eHz or 1x 3-point; meter type 44 kW variant: 2x eHz

### Mechanical design

Dimension	1797 x 425 x 490 mm (H x W x D)
Weight	depending on version 95-98 kg
Operating temperature range	-25 °C to +40 °C* <span style="float: right;">* 24 h ≤ 35 °C</span>
Installation site	≤ 2.000 m (altitude above sea level)
Relative humidity	5 to 95%, non-condensing
Protection class	IP54
Vandalism protection	IK10
Mounting type	Floor mounting on concrete foundation   prefabricated foundation available
Mechanical environmental conditions	M2

# Technical information

## Electrical version

Grid connection	Mains connection: 3P+N+PE, up to 95 mm <sup>2</sup> copper and aluminum / TAB-compliant mains connection with standard meter panel and house connection box with single-occupancy meter panel up to 30 kVA and 50 A meter fuse according to VDE-AR-N 4100; optional double-occupancy meter panel (BKE-I only) 2 x 22 KVA and 35 A meter fuses each
Security	Fuses per charging point: 3 x 32 A (on power board); RCD type A per charging point with additional DC residual current monitoring 6 mA; temperature derating; contactor sticking detection
Lightning and overvoltage protection	Optional combination arrester Cat. I+II+III AC according to DIN EN 61643-11 Optional combination arrester for data line in accordance with DIN EN 61643-21
Load management	Static and dynamic load management included (local, Modbus TCP, MQTT and OCPP); see operating instructions for details
Specific functions	i-MiEV detection, Mode 3s detection
Status display	LED status display integrated in topper element (remote visibility) Fault detection through different flashing codes
Calibration law	Conformity with calibration law as standard
Energy meter	DIN rail meter compliant with calibration law
Standby consumption	approx. 20 watts
Electromagnetic environmental conditions	E1

## Connectivity

Monitoring	Monitoring and diagnostics via OCPP1.6 (OCPP2.1 in preparation)
Remote maintenance	Extensive remote maintenance options via OCPP
Update options	USB, web interface, Backend
WebInterface	The Technagon web interface can be used to configure the most important parameters that are required for individual operation.
External IT systems	Standard Ethernet connection (LAN) and mobile phone connection via 4G modem

## Billing and customer management

Billing	by means of signed, calibration-compliant data records via OCPP
Long-term storage in compliance with calibration law	Local and physically accessible storage of charging data for 8 years via SD card
Customer management	via OCPP or local whitelist (csv import) Optional payment option via Giro-e (EC card)

## Standards

Charging processes	IEC 61851-1 (Mode 3)
Connections	IEC 62196 series
Security	IP 54 according to IEC 60529, IEC 62955, IEC 61439-1, IEC 61439-7, protection class 1 (with protective conductor), CE "Class A" in accordance with EU Directive 2014/30/EU
Calibration law	REA document 6-A, PTB requirement 50.7
VDE-AR-N 4100	Conformity given, after consultation with local energy supplier

# Technical information

## Shared backend providers

be.energised, Chargepoint, ChargeCloud, evway, Smartlab, Lichtblick, eRound, reev, Vaylens, Monta, MSU, E-Flux and more.

## Shared payment providers

GLS, EV-Pay, Hectronic and more.

## Shared load management providers

TQ, TMH, Smart1, Wago, IO-Dynamics and more.

Subject to technical changes

## Basic version

Article no.	Description
40069.166	Charging station TEP4 HAK with domestic connection box; compliant with calibration law, 2x charging socket; meter type 30 kW variant: 1x eHz or 1x 3-point; meter type 44 kW variant: 2x eHz

## Options and accessories

Article no.	Description
40069.150	Option of attached cable - straight cable length 5.5 m (note: the usable length of the cable is limited due to the spiralization)
40069.152	Double clamp (up to max. 35 mm <sup>2</sup> ) (mains connection clamp, with which another charging station can be supplied in parallel)
40069.153	Backend pre-configuration
40069.157	Overvoltage arrester DEHNpatch (Ethernet connection)
40069.158	Energy supplier contact (I/O port for possible requirements from energy suppliers)
40069.468	Mobile communications configuration package
40069.161	Direct payment system via Giro-e (only cards with the „Girocard“ symbol can be used) Business account with billing partner GLS Bank required separately
40069.177	Credit card terminal instead of a charging point (mobile phone connection in the terminal by default, additional network cable required for LAN)
40069.234	Ex works installation of a credit card terminal (customer provision required)
40069.328	Foiling ex works TEP4 HAK - Full foiling
40069.329	Foiling ex works TEP4 HAK - Partial foiling front and side panels
40069.327	Foiling ex works TEP4 HAK - Partial front foiling
40069.195	Prefabricated concrete foundation TEP4 HAK
40069.162	Foundation anchor TEP4 HAK
40069.296	Charging module cover (temporary cover)
40069.699	Preparation Pay in the front panel (mounting plate required separately depending on the credit card terminal)
40069.703	Product data export

# Meter cabinet equipment

Article no.	Description
40069.350	1 x eHz - 50 A TT
40069.351	2 x eHz - 35 A TT
40069.352	1x 3P - 50 A TT
40069.565	1 x eHz - 50 A TN-S
40069.566	2 x eHz - 35 A TN-S
40069.567	1x 3P - 50 A TN-S
40069.167	Power supply for SmartMeter Gateway in the RFZ (only for eHz)
40069.168	RJ45 LAN network connector in the RFZ (only for eHz)
40069.312	Overvoltage protection in the NAR (combined arrester Cat I+II+III)

## The uniqueness of Technagon

Our products are much more than simple charging stations. They embody intelligence, sustainability and elegance. Discover our entire portfolio at: [technagon.de/](https://technagon.de/)



# Contact

---

Technagon GmbH  
Brunnwiesen 38  
D-94481 Grafenau

Phone: +49 / 8555 / 51700-00  
Mail: [office@technagon.de](mailto:office@technagon.de)  
Web: [www.technagon.de](http://www.technagon.de)

